

English

Register and win!
www.kaercher.com

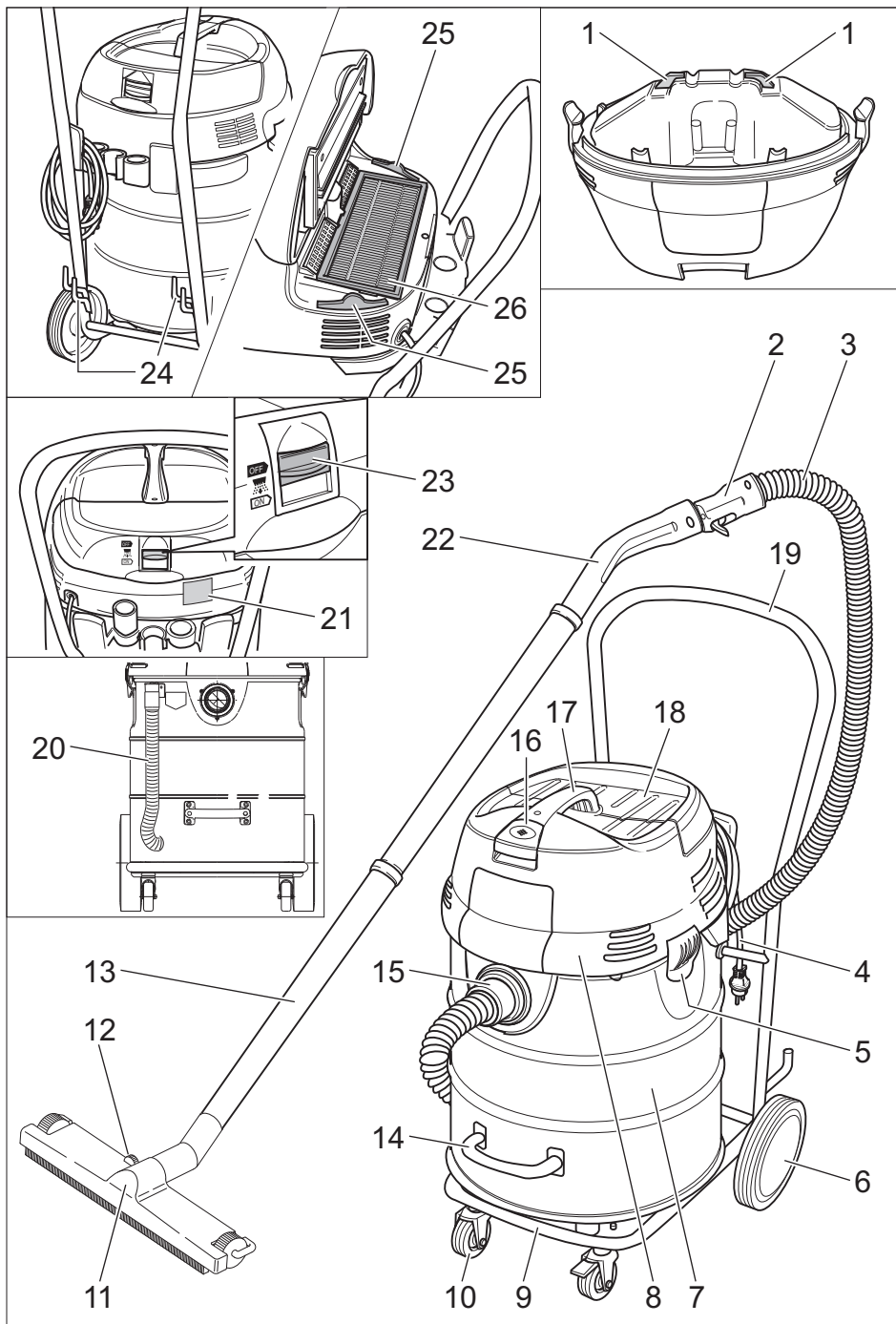

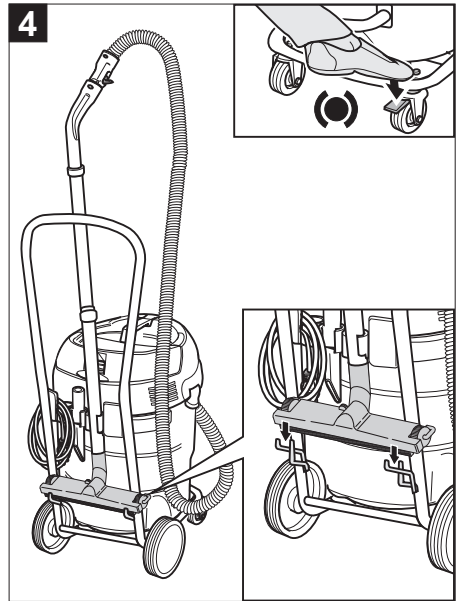

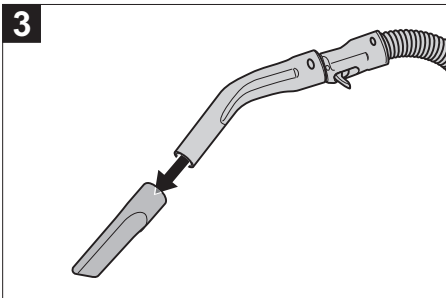
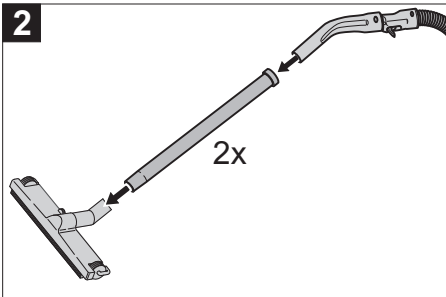
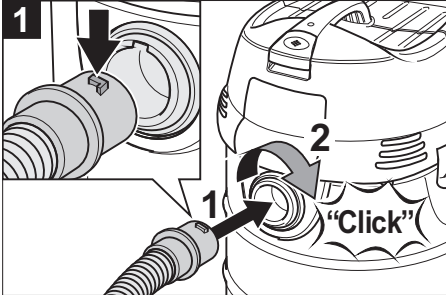
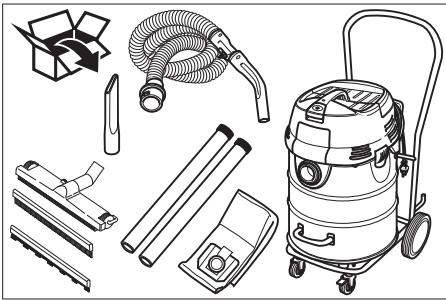

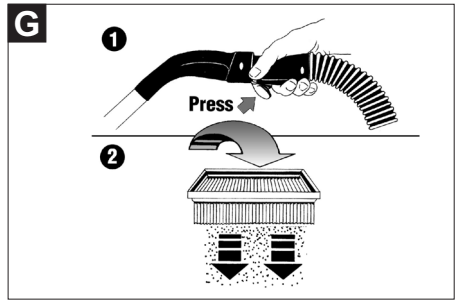
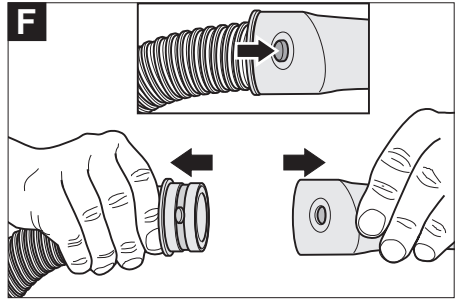
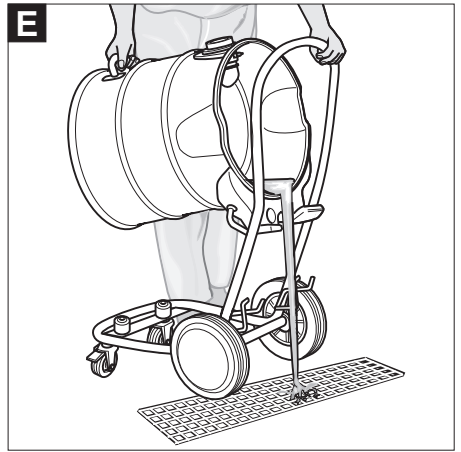
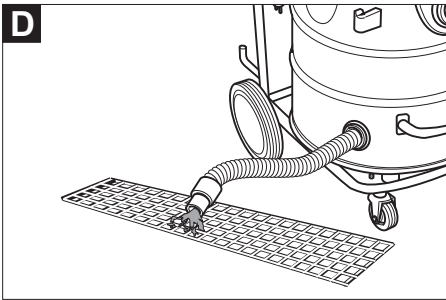
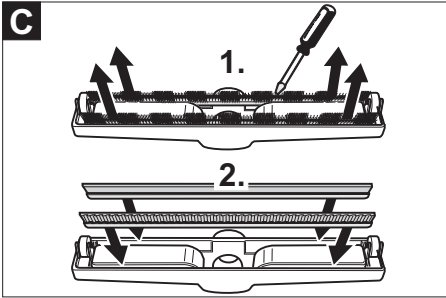
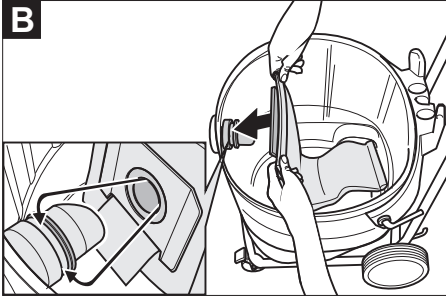
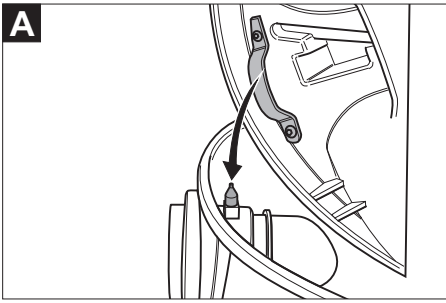



Please read and comply with these original instructions prior to the initial operation of your appliance and store them for later use or subsequent owners.

- Before first start-up it is definitely necessary to read the safety indications Nr. 5.956-249!
- The non-compliance of the operating and safety instructions may lead to damages of the appliance and to dangers for the operator and other persons.
- In case of transport damage inform vendor immediately

Contents

Environmental protection . .	EN . . . 1
Symbols in the operating instructions	EN . . . 1
Proper use	EN . . . 1
Device elements	EN . . . 2
Start up	EN . . . 2
Operation	EN . . . 3
Transport	EN . . . 3
Storage	EN . . . 3
Maintenance and care . . .	EN . . . 3
Troubleshooting	EN . . . 4
Warranty	EN . . . 5
Accessories and Spare Parts	EN . . . 5
Technical specifications . . .	EN . . . 6

Environmental protection



The packaging material can be recycled. Please do not throw the packaging material into household waste; please send it for recycling.



Old appliances contain valuable materials that can be recycled; these should be sent for recycling. Batteries, oil, and similar substances must not enter the environment. Please dispose of your old appliances using appropriate collection systems.

Notes about the ingredients (REACH)

You will find current information about the ingredients at:

www.kaercher.com/REACH

Symbols in the operating instructions

Danger

Immediate danger that can cause severe injury or even death.

Warning

Possible hazardous situation that could lead to severe injury or even death.

Caution

Possible hazardous situation that could lead to mild injury to persons or damage to property.

Proper use

Warning

The appliance is not suitable for vacuuming dust which endangers health.

- The machine is meant for dry and wet cleaning of floors and walls.
- This appliance is suited for the commercial use, e.g. in hotels, schools, hospitals, factories, shops, offices, and rental companies.
- The ambient temperature must not exceed 40 °C during operation.
- The appliance should never weigh more than 100 kg with additional loads.

Device elements

- 1 Electrodes
- 2 Handle "filter dedusting"
- 3 Suction hose
- 4 Power cord
- 5 Suction head lock
- 6 Wheel
- 7 Dirt receptacle
- 8 Suction head
- 9 Tilting chassis
- 10 Steering roller
- 11 Floor nozzle
- 12 Height adjustment of the floor nozzle
- 13 Suction tube
- 14 Container handle
- 15 Suction support
- 16 Main switch
- 17 Carrying handle
- 18 Filter cover
- 19 Push handle
- 20 Drain hose
- 21 Nameplate
- 22 Bender
- 23 Slide for filter cleaning
- 24 Floor nozzle holder
- 25 Exhaust filter
- 26 Flat fold filter

Start up

Caution

The flat pleated filter must always be in place while vacuuming.

Anti-static system

Illustration **A**

- The appliance is earthed up to the suction nozzle.
- Static charge is deflected by providing earthing to the connection nozzles. This prevents the formation of sparks and current shocks due to attachments (option) with electrical conductivity.

Dry vacuum cleaning

- When vacuuming fine dust, you may also use an additional paper filter bag or a membrane filter (special accessory).

Inserting the paper filter bag

Illustration **B**

- Release and remove the suction head.
- Insert the paper filter bag or the membrane filter (special attachment).
- Insert and lock the suction head.

Wet vacuum cleaning

Inserting the rubber lips

Illustration **C**

- Remove the brush strips.
- Install the rubber lips.

Note: The structured side of the rubber lips must point outwards.

Remove the paper filter bag

- If the appliance is used to vacuum wet dirt the paper filter bag or the membrane filter (special accessory) must always be removed.
- It is recommended to use a special filter bag (wet) (see Filter systems).

Drain off dirt water

Illustration **D**

- Drain off dirty water through the drainage hose.

Emptying the container fully

Illustration **E**

- Lock parking brake.
- Hold the container at the handle and tilt it by raising it.
- Empty the container fully.

General

- If wet dirt is vacuumed with the upholstery or crevice nozzle or if water is sucked up from a container it is recommended to deactivate the "Filter Dedusting" function.
- If the maximum liquid level is reached the appliance will turn off automatically.
- **In case of non-conductive liquids (such as emulsion drilling fluids, oils, and greases) the appliance is not turned off when the container is full. The filling level must be continuously monitored and the container must be emptied in time.**
- After the wet vacuuming: Clean the flat folded filter with the filter cleaning. Clean the electrodes with a brush. Clean the container with a damp rag and dry it.

Clip connection

Illustration

The suction hose is equipped with a clip system. All C-40/C-DN-40 accessories can be connected.

Operation

Turning on the Appliance

- ➔ Plug in the main plug.
- ➔ Switch on the appliance at the main switch.

Filter dedusting

Note: A filter dedusting every 5 to 10 minutes will increase the life of the flat folded filter.

- Switch off filter dedusting:
 - ➔ Push the slide upward.
- Switch on filter dedusting:
 - ➔ Push the slide downward.

Illustration

- ➔ Press and hold the switch on the handle for several seconds while the filter cleaning is turned on. The flat folded filter is automatically cleaned through an air jet (pulsating sound).

Height adjustment of the floor nozzle

- ➔ Turn the adjustment screw in a clockwise direction: High position of the floor nozzle
- ➔ Turn the adjustment screw in an anti-clockwise direction: Low position of the floor nozzle

Turn off the appliance

- ➔ Switch off the appliance at the main switch.
- ➔ Pull out the mains plug.

After each operation

- ➔ Empty the container.
- ➔ Vacuum and wipe the appliance inside and outside with a damp cloth.

Transport

Caution

Risk of injury and damage! Observe the weight of the appliance when you transport it.

- ➔ Remove the suction pipe with the floor nozzle from the holder. Hold the appliance at the handle and at the suction pipe to transport it.
- ➔ When transporting in vehicles, secure the appliance according to the guidelines from slipping and tipping over.

Storage

Caution

Risk of injury and damage! Note the weight of the appliance in case of storage.

This appliance must only be stored in interior rooms.

Maintenance and care

Danger

First pull out the plug from the mains before carrying out any tasks on the machine.

Exchanging the flat pleated filter

- Open filter door.
- Replace the flat pleated filter.
- Close the filter door, it must lock into place.

Replace exhaust filter

- Open filter door.
- Replace exhaust filter.
- Close the filter door, it must lock into place.

Cleaning the electrodes

- Release and remove the suction head.
- Clean the electrodes with a brush.
- Insert and lock the suction head.

Troubleshooting

Danger

First pull out the plug from the mains before carrying out any tasks on the machine.

Suction turbine does not run

- Check the receptacle and the fuse of the power supply.
- Check the power cable, the power plug and electrodes of the device.
- Turn on the appliance.

Suction turbine turns off

- Empty the container.

Suction turbine does not start again after the container has been emptied

- Turn off the appliance and wait for 5 seconds, turn it on again after 5 seconds.
- Clean the electrodes as well as the space between the electrodes with a brush.

Suction capacity decreases

- Remove choking of suction nozzle, suction tube, "filter dedusting" handle, suction hose, or flat folded filter.
- Exchange the paper filter bag.
- Filter dedusting: Repeatedly press the button on the handle while the filter cleaning is turned on.
- Ensure the filter cover properly locks into place.
- Clean or replace the membrane filter (special accessory) under running water.
- Replace the flat pleated filter.
- Check drain pipe for leaks.

Dust comes out while vacuuming

- Check for proper installation of the flat pleated filter.
- Replace the flat pleated filter.

Automatic shut-off (wet vacuum cleaning) does not react

- Clean the electrodes as well as the space between the electrodes with a brush.
- Continuously check the filling level in case of non-conductive liquid.

Filter dedusting switches permanently

- Release the blocked suction nozzle or end of the hose.
- Stop the continuous vacuuming from the liquid container or switch the filter cleaning off.
- Remove choking of suction nozzle, suction tube, "filter dedusting" handle, suction hose, or flat folded filter.
- Replace the flat pleated filter.

Filter cleaning is not working

- Suction hose is not connected.

Automatic filter cleaning cannot be switched off

→ Inform Customer Service

Automatic filter cleaning cannot be switched on

→ Inform Customer Service

Warranty

The warranty terms published by the relevant sales company are applicable in each country. We will repair potential failures of your appliance within the warranty period free of charge, provided that such failure is caused by faulty material or defects in manufacturing. In the event of a warranty claim please contact your dealer or the nearest authorized Customer Service centre. Please submit the proof of purchase.

Accessories and Spare Parts



- Only use accessories and spare parts which have been approved by the manufacturer. The exclusive use of original accessories and original spare parts ensures that the appliance can be operated safely and trouble free.
- At the end of the operating instructions you will find a selected list of spare parts that are often required.
- For additional information about spare parts, please go to the Service section at www.kaercher.com.

Technical specifications

		NT 72/2 Eco Tc
Mains voltage	V	120
Frequency	Hz	1~ 60
Rated current	A	18
Container capacity	l	72
Filling quantity (liquid)	l	56
Air volume (max.)	l/s	2x 54
Negative pressure (max.)	kPa (mbar)	23,5 (235)
Type of protection	--	IPX4
Protective class	--	I
Suction hose connection (C-DN/C-ID)	mm	40
Length x width x height	mm	680 x 520 x 1000
Typical operating weight	kg	31,0
Max. ambient temperature	°C	+40
Values determined to EN 60335-2-69		
Sound pressure level L_{pA}	dB(A)	74
Uncertainty K_{pA}	dB(A)	1
Hand-arm vibration value	m/s ²	<2,5
Uncertainty K	m/s ²	0,2

Power cord	SJTW-A 3x14 AWG	
	Part no.:	Cable length
VEX	6.648-919.0	10 m

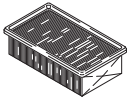
Filtersysteme / Filter Systems / Système de filtres

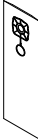
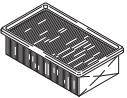











					
	Flachfaltenfilter * Flat pleated filter * Filtre plat à plis *	Papierfiltertüte 3-lagig (reißfest) * Paper filter bag triple layered (tenacious) * Sachet filtre à 3 épaisseurs (résistant à la rupture) *	Membranfilter Diaphragm filter Filtre à membrane	Spezialfiltertüte, nass Special filter bag, wet Sachet filtre spécial, mouillé	Flachfaltenfilter (PES) * Flat pleated filter (PES) * Filtre plat à plis (PES) *
Bestell-Nr. Order No. Numéro de référence	6.904-283	6.904-285	6.904-282	6.904-252	6.904-284
Menge Quantity Quantité	1	5	1	5	1
Normalstäube Normal dust Poussières normales	X	X	X		
Feinstäube Fine dust Poussières fines	X	X	X		
Abrasiv Stäube Abrasive dust Poussières abrasives	X	X	X	X	
Flüssigkeiten, nasser Schmutz Liquids, wet dirt Liquides, saletés humides				X	X

* BIA C geprüft, Rückhaltevermögen $\geq 99,9\%$





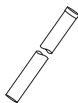

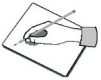

* BIA C approved, Retention $\geq 99,9\%$

* Contrôle BIA C, Conservation $\geq 99,9\%$

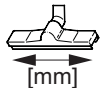
Zubehör / Accessories / Accessoires

		∅ [mm]	 [m]	 [mm]
	4.440-679 K 4.440-728 K/EL	CDN 40 CDN 40	4,0 4,0	
	4.060-474 K 4.060-533 K/EL	C 40 C 40		
	6.906-321 K 6.906-279 K	C 40 C 40	4,0 10,0	
	6.906-344 K	C 40 Verlängerung, extension, rallonge	2,5	
	5.407-109 K/EL 5.407-111 K/EL	C 40 --> DN 35 C 40 --> DN 40		
	5.407-113 K/EL	C 40 --> C 35		
	5.031-904 K 5.032-427 K/EL	DN 40 DN 40		
	6.902-081 M 6.906-531 M	DN 40 DN 40	0,5 1,0	
	6.906-554 K 6.903-018 M 6.903-051 M	DN 40 DN 40 DN 40		360 370 450

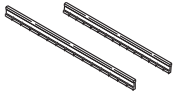
Zubehör / Accessories / Accessoires

		∅ [mm]		
	6.903-033 K 6.905-817 M	DN 40 DN 40	0,30 0,40	
	6.902-105 G/Oil	DN 40	0,20	
	2.637-217 K	DN 40		
Umbausatz für nichtleitende Medien, Upgrade kit for non-conducting media, Kit de modification pour les fluides non conducteurs	2.640-426			
	6.905-877 G 6.903-062 G 6.903-081 Oil 6.903-063 G 6.906-146 Oil			360 370 370 450 450
	6.905-878 K 6.904-064 K 6.904-065 K			360 370 450

EL = elektrisch leitend, electrical conductive, conducteur électrique

K = Kunststoff, Plastic, Plastique

C = Clip-Verbindung, Clip connection, Connexion de clip

DN = Konus-Verbindung, Cone connection, Connexion de cône

M = Metall, metal, métal

G = Gummi, Rubber, Caoutchouc

Oil = ölbeständig, oil resistant, résistant à l'huile

NT 72/2 Eco Tc

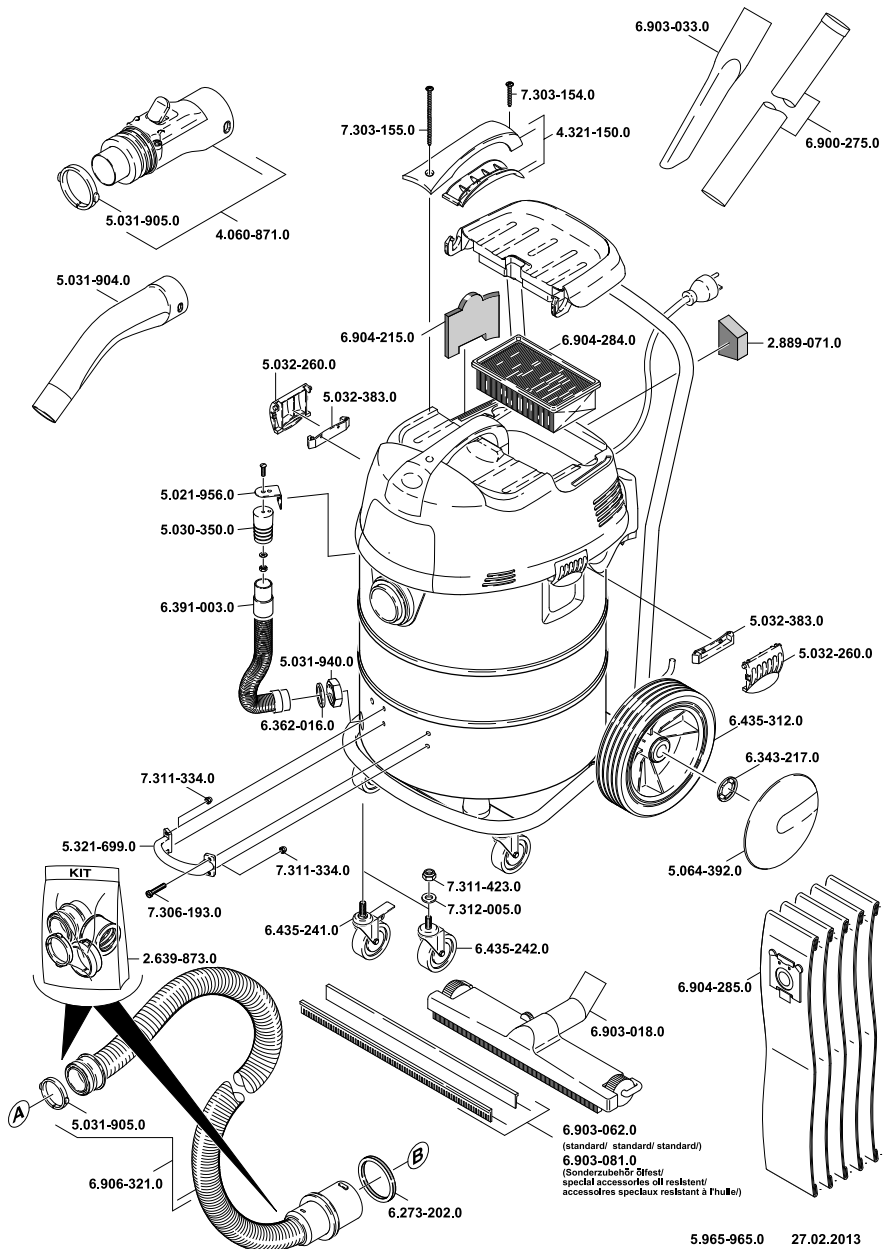



<http://www.kaercher.com/dealersearch>

